



Orion Box 24V DC

CHAIN SLIDING MOTOR FOR RESIDENTIAL APPLICATIONS



STEEL CASE

- Residential electromechanical chain sliding operator for gate up to 700 lbs
- It is very smooth and exceptionally quiet
- It is a unique compact motorized gear box
- Metal cover with cataphoresis treated box
- Slow down in opening/closing with USER 1 - 24V DG
- Reverse on obstruction
- Very easy manual release with key
- Mechanical limit switch
- Receiver included
- **Ball bearing on the wheels**
- Buzzer alarm.
- **Built-in battery back up system**
- In option solar panel (KIT SUNNY)
- Battery back-up 7 Ah included
- Duty Cycles*: 40 %

* Duty Cycles depend on gate size and installation



Ball bearing wheels



Limit switches



User friendly manual release with key

CODE	DESCRIPTION	MAX LEAF WEIGHT	MAX LEAF LENGTH	DUTY CYCLES %	PCS PER PALLETS
1120MECOBOX-CSA	ORION BOX 24V with steel case	700 lbs	20 feet	40	12

CONTROL BOARDS

CODE	DESCRIPTION
2302A24U1DGR	USER 1 - 24V DG Replace (only circuit)

ACCESSORIES



23106430 *
Kit SUPER SUNNY 85W
85W solar panel + charger
+ battery 33Ah



12710651
Case in stainless steel

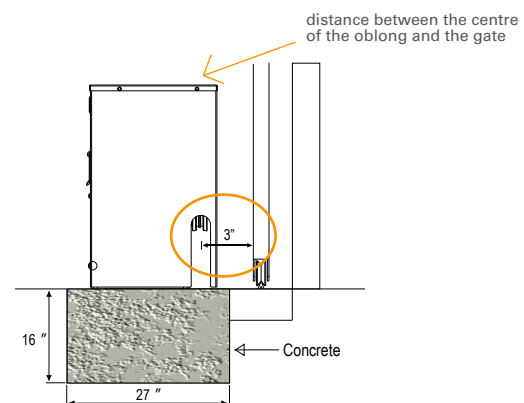

Dimensions (inches)

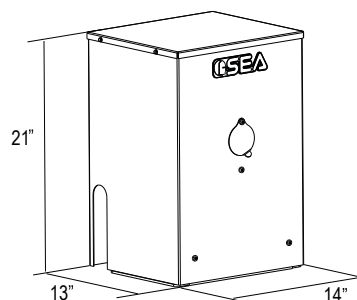

PACKAGE ORION BOX

- N.1 Operator ORION BOX with 24V control board
- N.20 Feet of chain (type 40)
- N.1 Receiver
- N.1 Remote control 433 Mhz
- N.1 Foundation plate
- N.1 Installation accessories Kit
- N.1 Installation instructions and general notice
- N.1 Warning signboard



NB: ESUN Q 23101104 to combine with BAT7 23106305
(* Plastic box not included)